

Valve Extension Spindle

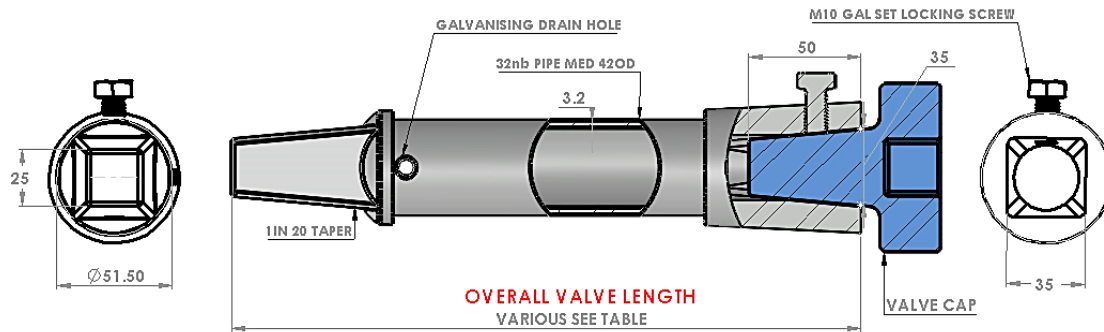

Valve Extension Spindle Technical Data

The EJ Hadaway range of Australian standard valve keys comply with AS/NZS 2638 gate valves for waterworks purposes and are used to open gate valves and services.

They are manufactured by welding a hot forged male and female end to pipe then hot dipped galvanised to AS/NZS 4680.

Hot forged ends provide a stronger product than cast iron or plastic.

Our spindles have been mechanically torque tested to 600Nm with no distortion and meet all dimensional requirements of the relevant Australian Standards. They are Australian made in Dandenong Victoria.

Spindles come with a M10 x 20 galvanized setscrew to allow retention on the spindle cap.

Our range starts from 150mm up to 6m long.

The standard sizes from 150mm to 2m are kept in stock and special lengths can normally be made within 48 hours.

Australian standard spindle extensions in 316ss can be supplied to order.

Valve spindle extensions are used to reach sluice and water mains valves that are under ground and are deeper than the length of a Sluice valve key (part number- EJH-VK-SLUICE).

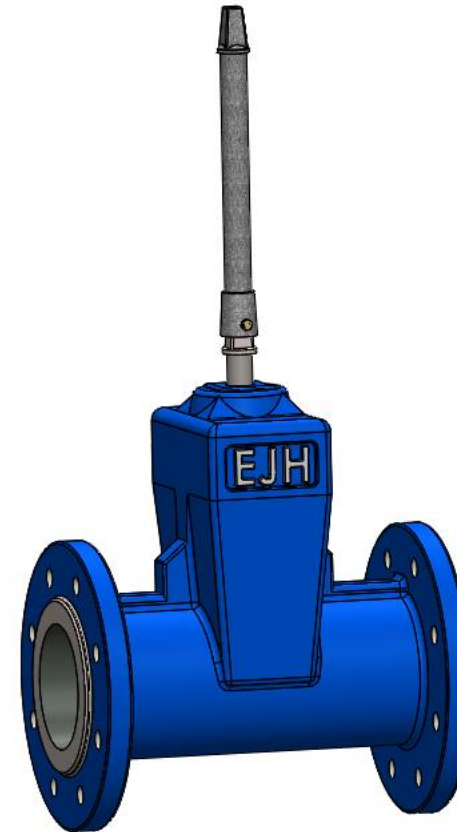

Overall Spindle Length	Part Number
150	EJH-VES0150SS
225	EJH-VES0225SS
300	EJH-VES0300SS
375	EJH-VES0375SS
450	EJH-VES0450SS
600	EJH-VES0600SS
750	EJH-VES0750SS
900	EJH-VES0900SS
1000	EJH-VES1000SS
1100	EJH-VES1100SS
1200	EJH-VES1200SS
1300	EJH-VES1300SS
1500	EJH-VES1500SS
1600	EJH-VES1600SS
1700	EJH-VES1700SS
1800	EJH-VES1800SS
1900	EJH-VES1900SS
2000	EJH-VES2000SS
2400	EJH-VES2400SS

For effective length of spindle extension, deduct 50mm from overall length



Give EJ Hadaway a call or email:



E.J.HADAWAY
HOT FORGING & CUSTOM FASTENERS

admin@ejhadaway.com.au

 (03) 9706 6102